

Modification in the Design of a Service Truck Used in the Mining Sites

Simons Anthony, Ofori-Ntow Eric jnr

Abstract— Heavy duty (off- high- way) trucks used in the mines and road construction sites need to be supplied with fuel and lubricants on the work field without moving them to the fuel filling stations due to the time lock up required to move them and the space to accommodate them. A service truck designed for the purpose of supplying the off- high- way trucks with these fuel and lubricants has its supplying hoses exposed to dust and water when it rains. Subsequently introduce dust and water to the lubricants and fuel during supply. The dust and water cause regular breakdown of the trucks' gear box, hydraulic pumps and valves. Laboratory analysis of the used oil from the off- high- way trucks indicates high rate of foreign materials such as dust. This paper looks at how best to modify the design on the service truck to eliminate the exposure of its supplying hoses from dust and water which are the main contaminants found in the used oil analysis. Manufacturing techniques, design procedures and the effect of the environment were considered in selecting materials for the modification. It is concluded that, the provision of a galvanized steel formwork to house the supplying hoses will prevent dust and water from getting into contact with the fuel and lubricants, therefore reducing the rate of breakdown of the off- high- way trucks. This will ensure that the trucks are available all the time.

Index Terms— Maintenance, Downtime, Formwork, Modification, Dust, Water, Fuel, Lubricant.

1 INTRODUCTION

A service truck supplies fuel, grease, hydraulic oil and other lubricants to earth moving trucks on the work field without necessarily moving these trucks to the workshop. Per their design, the dispensing nozzles on the service truck are always exposed to dust and water when they are discharging lubricants to heavy duty truck on the site. These dust and water contaminate the fuel, grease, hydraulic oil and other lubricants. Consequently, increasing the wear rate of machine components which leads to increase downtime, high cost of maintenance and decrease in the truck utilization. The objective of this work is to modify the design of the service truck to make it dust and water-free. The design of a dust free fuel and lubrication system on a service truck will lead to reduction in the cost of maintenance of trucks, increase truck utilization and reduce the work at the workshop.

2 DESIGN PROCEDURE

2.1 Existing Design of Service Truck

The existing design of Service Truck has its supply nozzles which supply engine oil, hydraulic oil, fuel, water and grease to the heavy duty trucks exposed to dust and water (when it rains). The dust gets into the opening of the supply nozzles during movement of the service truck from the workshop to the pit. This dust gets into contact with lubricants and fuels, consequently causing abrasive wear of bearings, gears and

other components which are in relative motion to each other. Consequently, this increases downtime of truck (unavailability), cost of maintenance and decreases truck utilization.

2.2 Arrangement of the Supply Nozzles and Tanks

Fig 1 and 2 show the supply nozzles and how they are exposed to dust. Each hose supplies a particular oil or fuel, such as water, TC-50, TC 15-40, TC-10 and grease. The hose which supplies the grease has a grease gun coupled to it to aid in greasing of bearings.



Fig 1 Side View of Existing Service Truck

- Simons Anthony is currently a senior lecturer at the Department of Mechanical Engineering, University of Mines and Technology, Ghana-Tarkwa, PH-+233(0)208168329. E-mail: remasd@yahoo.com, asimons@umat.edu.gh
- Ofori-Ntow Eric jnr is currently an Assistant lecturer at the Department of Mechanical Engineering, University of Mines and Technology, Ghana-Tarkwa, PH-+233(0)544714483. E-mail: onejunior2003@yahoo.com



Fig 2 Back View of Existing Service Truck

2.3 Modification of the Design

A proposed design was made to curb the deposit of dust and water on the dispensing nozzles of the Service Truck. The modification was done using manufacturing technology and machine design to form a structure to cover the supplying nozzles from dust and water. This includes selection of material, selection of various components and determining stiffness of bolts, joints and the spring rate etc.

2.4 Selection of Material

The material for the formwork (modification) was selected based on the following factors;

1. Processing characteristics
2. Performing characteristics
3. Environmental profile
4. Cost.

Based on the above criteria, galvanized steel and mild steel were found to be the right materials for the work, however, galvanized steel is preferred due to its superior long life and its resistance to corrosion. The dimension of the sheet on market is 2.4384 m by 1.2192 m by 0.00125 m (market survey). Fig 3 shows the isometric drawing of the proposed formwork for the modification on the service truck.

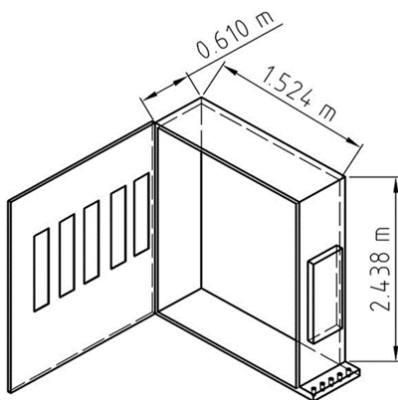

Fig 3 Proposed Steel Formwork for the Modification

The total area of the form to be used is tabulated in Table 1 below. One sheet of dimension 2.4384 by 1.2194 is added for the production of smaller gates leading to each supply nostril (*).

Table 1 Dimensions for the formworks parts

Length [m]	Breadth [m]	Quantity	Area Needed[m ²]
2.4384	1.5240	2	7.4322
1.5240	0.6095	2	1.8578
2.4384	0.6095	2	2.9724
2.4384	1.2194	1 *	2.9734
Total area of sheet required			15.2358

Number of galvanized sheets (*N*) required, can be calculated as

$$N = \frac{\text{Total area required of sheet require}}{\text{Area of one sheet}} \quad (1)$$

$$N = \frac{152358}{24384 \times 1.2192}$$

$$N = 5.1240$$

$$N \approx 6 \text{ pieces}$$

2.5 Selection of Fasteners

According to [1], fasteners can be either permanent such as rivets or non-permanent such as bolts and nuts. Bolt and nut were chosen as the fasteners to hold the Formwork firmly in place since they can be used in a variety of applications in different grades and again aid easy removal of formwork for maintenance. Because air resistance will be exerted on the structure when the service truck is moving, the bolt diameter should be determined. To find the diameter of the bolt, the air resistance force (*F*) should be first determined to aid in the calculation of the safe withdrawal strength (*W_s*) of each bolt. The value of safe withdrawal strength is then matched to the bolt diameter from Table 2.

According to [2], the air resistance (force) is determined by the formula

$$F = 0.033 \times A \times V^2 \quad (2)$$

where,

F is the total air load against structure area (vertical projection) in pounds.

A is the total area of the structure exposed to the air resistance in inches.

V is the maximum local air velocity which is also taken to be the maximum truck speed (85 mph).

A recommended safety factor of 1.3 is considered to cater for over pressures.

$$F = 0.033 \times 60 \times 95.984 \times (1.3^2 \times 85^2)$$

$$F = 232053lb = 1052578Kg$$

The safe withdrawal strength is calculated using the expression below;

$$W_S \geq \frac{F}{\frac{L}{S} + 1} \quad (3)$$

$$W_S \geq \frac{232053}{5/0.5 + 1}$$

$$W_S \geq 2109.73psi$$

$$W_S \geq 2109.73 \times 0.06895 = 145.465bar$$

where,

L is the length of row of connector (5 ft)

S is the safe spacing of connectors along the wall (0.5 ft)

With this pressure, the corresponding bolt diameter from Table 2 below is 3/4 inch (19 mm) which can withstand the air resistance when the truck is moving at the maximum speed of 85 mph.

Table 2 Allowable Anchor Bolt Loads (A307 Bolts)

Bolt Diameter, [in]	Minimum Imbedment [in]	Minimum Edge d. [in]	Type of Load	Allowable Load, [lb/bolt] Solid masonry Grouted masonry concrete, [psi]. 2000 3000			
				2000	2000	3000	3000
1/2	4	3	Withdrawal	680	950	950	950
			Shear	350	2000	2000	2000
5/8	4	3 3/4	Withdrawal	680	1500	1500	1500
			Shear	500	2750	2750	3000
3/4	5	4 1/2	Withdrawal	1060	2250	2250	2250
			Shear	750	2900	2940	3560
7/8	6	5 1/2	Withdrawal	1530	3200	3200	3200
			Shear	1000	3350	3580	4150

(Source: Robert B. Butler, 2002)

Table 3 Constants Used in Joint Stiffness Formula

Material	Poisson's ν	Modulus of Elasticity		Numerical Constants	
		E, [GPa]	M [psi]	Ai	Bi
Steel	0.2910	206.800	30.000	0.78715	0.62873
Aluminum	0.3340	71.000	10.000	0.79670	0.63816
Copper	0.3260	118.600	16.000	0.79568	0.63553
Gray cast iron	0.2110	100.000	14.600	0.77871	0.66616

(Source: Wileman et al. 1991)

Table 4 Typical Properties of Common Spring Materials

Common Name	Specification	Modulus of Elasticity E [psi]	Shear modulus of Elasticity G [psi]	Density $[\rho \text{ lb/in}^3]$	Maxi Service of Temp. [°F]
High Carbon Steel					
Music Wire	AST A228	30 ×10 ⁶	11.5 ×10 ⁶	0.283	250
Hard-drawn	AST A227	20 ×10 ⁶	11.5 ×10 ⁶	0.283	250
Stainless Steel					
Martensitic	AISI 410,420	29 ×10 ⁶	11 ×10 ⁶	0.280	500
Austensitic	AISI 310,302	28 ×10 ⁶	10 ×10 ⁶	0.282	600
Nickel-Based Alloys					
Inconel 600	-	31 ×10 ⁶	11 ×10 ⁶	0.307	600
Inconel -750	-	31 ×10 ⁶	11 ×10 ⁶	0.298	1100
Ni-Span C	-	27 ×10 ⁶	9.6 ×10 ⁶	0.294	200

(Source: Schmid et al, 2014)

Table 5 Coefficients Used In Spring Equations

Material	Size Range, [mm]	Exponent, [m]	Constant A_p , [MPa]
Music Wire	0.10 – 6.5	0.145	2211
Oil- Tempered Wire	0.50 – 12.7	0.187	1855
Hard-Drawn Wire	0.70 – 12.7	0.190	1783
Chromium Vanadium	0.80 – 11.1	0.168	2005
Chromium Silicone	1.6 – 9.5	0.108	1974

(Source: Budynas and. Nisbett, 2011)

To calculate the bolt and joint stiffness as well as the dimensionless stiffness parameter and shear stress etc, the crest diameter (d_c) and root diameter (d_r) from Table 2, are 19 mm (5 in) and 16 mm (4.5 in) respectively. Considering the thickness of the galvanized steel and the base plate on the tuck on which the Formwork will be mounted, the bolt shank length (l_s) and the thread length (l_t) are to be 20 mm and 40 mm respectively and the frustum cone angle α is 30°.

Using Wileman’s equations, the bolt stiffness (k_b), joint stiffness (k_j) and the dimensionless stiffness parameter (c_k) are calculated. The value of the dimensionless parameter should be less than 1 to indicate that the values for both bolt and joint stiffness are acceptable. Using the equation

$$\frac{1}{k_b} = \frac{4}{\pi E} \left(\frac{l_s + 0.4d_c}{d_c^2} + \frac{l_t + 0.4d_r}{d_r^2} \right) \quad (4)$$

$$\frac{1}{k_b} = \frac{4}{\pi \times 206.8 \times 10^9} \left(\frac{0.02 + 0.4 \times 0.019}{0.019^2} + \frac{0.04 + 0.4 \times 0.016}{0.016^2} \right)$$

$$k_b = 1.587 \times 10^9 \text{ Nm}$$

Also,

$$k_b = E d_c A_i e^{B_i \frac{d_c}{L}} \quad (5)$$

where,

E modulus of elasticity,

A_i and B_i are numerical constants gotten from Table 3 above.

$$k_j = 2.068 \times 10^{11} \times 0.019 \times 0.78715 \times e^{0.62873 \frac{19}{60}}$$

$$k_j = 3.774 \times 10^9 \text{ N / m}$$

The value of the dimensionless stiffness parameter C_k can be calculated as,

$$C_k = \frac{k_b}{k_b + k_j} \quad (6)$$

$$C_k = \frac{1.587}{1.587 + 3.774} = 0.296$$

2.6 Hinge Selection

Both butt hinges and stays were selected for the two types of gates which are to be employed in the modification. The reason is that the stays will help the smaller gates to be self-locking making sure that the cabin is dust free. To ensure this, a soft door lining is used around the gates 4" (100 mm) butt hinge is for the main gate while 2" (50 mm) butt hinges for the smaller gates.

2.7 Spring Selection

A helical extension spring is selected to aid wind the supplying hoses back around their pulley on the truck. With mean coil diameter of 10 mm and wire diameter of 5 mm, the spring rate, index, transverse shear stress, ultimate strength in tension and torsional yield stress can be calculated as follows;

For static load, the transverse shear factor (k_d) is

$$k_d = 1 + \frac{0.5}{c} \quad (7)$$

where c is the spring index and is calculated as,

$$D/d = 10/2 = 5$$

where,

D means coil diameter

d is the wire diameter.

therefore,

$$k_d = 1 + \frac{0.5}{5}$$

$$k_d = 1.1$$

$$\text{preload, } p, = \frac{\pi \tau d^2}{8c} \quad (8)$$

As recommended by Barnes Group Inc, Let us assume the preload to be 30 N.

$$30 = \frac{\pi \times \tau \times 2^2 \times 10^{-6}}{8 \times 5}$$

Therefore, the shear stress is

$$\tau = 95.50 \text{ MPa}$$

For the spring rate k ,

$$k = \frac{dG}{8N_c C^3} \quad (9)$$

where,

N_c is number of active coils

G is shear modulus of elasticity obtained from Table 4.

$$k = \frac{2 \times 10^{-3} \times 7.928 \times 10^5}{8 \times 15 \times 5^3}$$

$$k = 0.1057 \text{ Nm}$$

The ultimate strength in tension S_{ut} is given by

$$S_{ut} = \frac{A_p}{8N_c C^3} \quad (10)$$

From Table 5, A_p a constant is 1783 MPa and m an exponent is 0.190

Therefore

$$S_{ut} = \frac{1783 \times 10^6}{0.002^{0.190}}$$

$$S_{ut} = 5.880 \text{ GPa}$$

The torsional yield stress (allowable shear stress), S_{sy} , is given by

$$S_{sy} = 0.4 S_{ut} \quad (11)$$

$$S_{sy} = 0.4 \times 5.880 \times 10^9$$

$$S_{sy} = 2.352 \text{ GPa}$$

2.8 Cost analysis

The purpose of a cost - benefit analysis is to give a set of quantitative metrics to help individuals or companies in their decision making.

In this work, a formwork was fabricated. The following materials and components were use;

1. Galvanized steel sheet
2. Bolts and nuts
3. Stay and butt hinges
4. Door lining and sealant

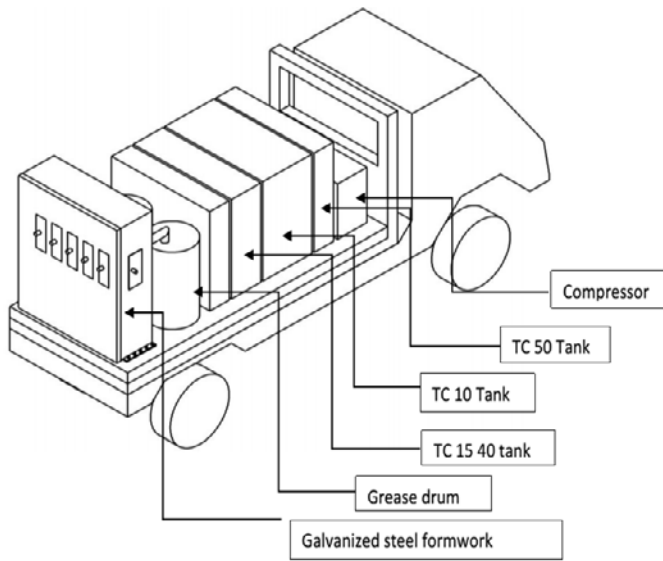

Fig 4 The proposed modification

Table 6 depicts the total cost of the fabrication.

Table 6 Cost of various components employed

Component	Quantity	Unit Price [Gh¢]	Amount [Gh¢]
Galv. steel	6	150.00	900.00
Bolts and nuts	50	2.00	100.00
Stay hinges	14	4.00	56.00
Door lining	-	-	100.00
Sealant	2	5.00	10.00
Fabrication	-	-	300.00
Spraying			300.00
Transportation			250.00
Total			2016.00
20% overhead			403.2
Grand Total			2419.2

2.9 CONCLUSIONS

It can be concluded that the system could be made dust and water free by the provision of the galvanized steel formwork on the supplying system. The formwork is of dimension 2.438 m by 1.524 m by 0.610 m and M19 bolts are used to fasten it onto the truck to withstand the air pressure on the structure at a maximum truck speed of 85 mph. The characteristics of the bolts are;

1. Shank and thread lengths of 20 mm and 40 mm respectively
2. Bolt stiffness of 1.58 GN/m
3. Join Stiffness of 3.774 GN/m

2.10 RECOMENDATIONS

The following are recommended to further curb the effects of dust and water in lubricants supplied to the heavy duty trucks at work field;

1. The technician using the truck should allow the dust to settle down before opening and pulling the supplying hose out.
2. The road leading to the pit where the truck is mostly used should be watered twice daily during the dry season.
3. When the truck is dirty, it should be washed immediately.
4. The exterior surfaces should be cleaned of dust before opening of the gates.
5. Transfer containers, funnels, and nozzles which are sometimes used should be cleaned before using them.

REFERENCES

- [1] T. F. Waters, Fundamentals of Manufacturing for Engineers, Taylor and Francis Group, (1996), pp. 132-138
- [2] R. B. Butler, Architectural Engineering Design, 1st Edition, McGraw-Hil, Two Penn Plaza, New York, (2002), pp 55-449.
- [3] B. J. Hamrock, R. S. Schmid, B. O. Jacobson, Fundamentals of Machine Elements, 2nd Edition, McGraw - Hill Companies Inc., New York, (2005) pp. 501-515.
- [4] R. S. Khurmi, J. K. Gupta, A Textbook of Machine Design, Eurasia House (PVT) Ltd., New Delhi, Multicolour Edition, (2005) pp. 17-44, 261-364 and 827-856.
- [5] W. A. J. Chapman, Workshop Technology Part 1, 5th Edition, J. W. Arrowsmith Ltd., Bristol, (1996) pp. 10-90.
- [6] Barnes Group Inc., Engineering Guide to Spring Design, (1987), pp. 21-120.
- [7] R. G. Budynas, J. K. Nisbett, Shigley's Mechanical Engineering Design, 9th edition. pp 410-557.
- [8] Wileman et al. (1991), ASME Journey of Mech. Design., 113, pp. 432-437